

Picture 5 shows, just for the record, a layout with a planetary gear, as a so called 'pot gear' within the drum. I personally started 15 years ago with

Here one of the stage engineering industry's most knowledgeable engineers describes both the standard units and also some less well-known attempts at producing efficient and quiet power flying hoists. He is preceded by a paper on the use of chain hoists and by an introduction to steel-band suspensions and how they can be used in the theatre.

supposed to be a 'silent' winch. The planetary gear is very loud and is referred to a high level even on levels even to a 2,000 watt

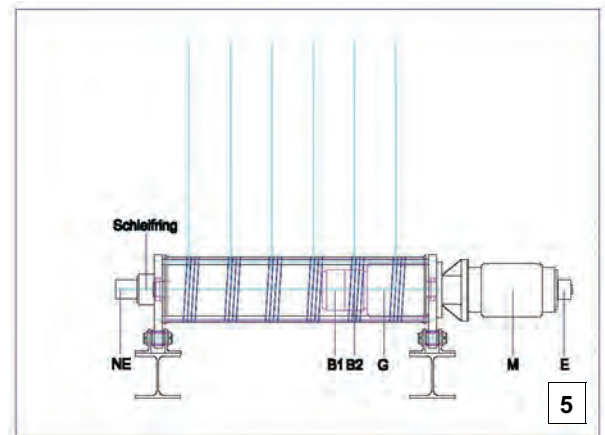

whispering winch® trade mark of Statec Bühnentechnik GmbH

Advantages: none

Disadvantages: many

Net result: not recommended!

Picture 6 shows a symmetrical layout with 2 gearboxes, motors and brakes each. This winch was shown at Showtech in Berlin 2001. The manufacturer advertised with the slogan of 'double safety' by the means of use of double components. While double brakes are necessary, it does not need two gearboxes in order to achieve double safety; one gearbox with a 2:1 factor is sufficient. Even though I do not know the initial criteria, I dare to say that this type of winch cannot be economical.

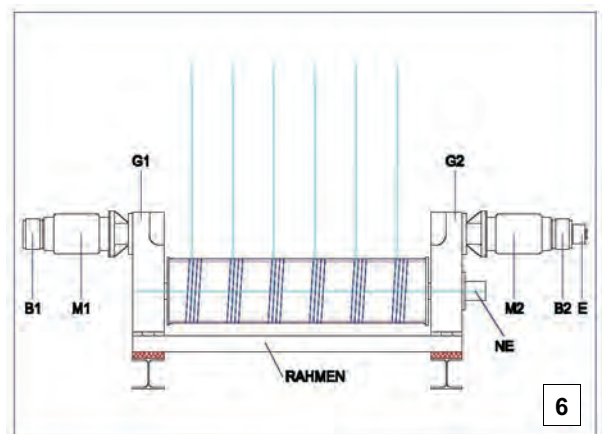

Picture 7 Just for reasons of completeness I want to show the principals of a vertical winch. This very narrow winch was developed to be installed in exchange for the old manual counterweight hoists in those shafts in the side walls of the stage tower. This winch consists of a vertically-standing steel tube on which the drum is supported by bearings at the top and bottom. The gearbox is mounted onto it and is held in position via a load sensor as a torque arm. The diverter pulleys are installed into a vertically movable carriage that moves parallel to the running wire-ropes. The motion of the carriage is achieved by an extension of the drum shaft machined to form a lead-screw with the same pitch as the drum grooves. With the wire-ropes turned through 90°, the fleet angles to the winding drum are therefore constantly normal to the drum grooves.

The installation of vertical winches in the "Theater an der Wien" in Vienna.



Photo: Waagner-Biro

